



AC MOTORS

**Monophasic**

# Grinders

## FEATURES

2 Pole Motor Voltages: 127V, 120V, 60Hz

Robust construction for industrial use.

Gray iron castings. Side hopper cover included.

Model	EHD-142-1	EHD-132-1	EHD-132-1	EHD-342-1
HP	1/4	1/3	1/2	3/4
RPM	3450	3450	3450	3450
Stones (Inches)	6 x 1/2 x 1/2	6 x 1/2 x 5/8	7 x 5/8 x 1	8 x 3/4 x 1
Distance between wheels	11 3/16	11 15/16	13 9/16	16 7/8
Shaft Diameter	2 1/2	1 1/2	5/8	3 1/4
Height to the center of the shaft	4 3/4	4 3/4	5 3/4	8 1/4
Aprox. Weight (kg.)	12	14	25	40



## Applications

They are mainly used in the Metal-Mechanics and construction industry to remove burrs and leftovers from metal parts in the preparation of areas for welding, sharpening of bits and burins.

## Performance

We have three presentations:  
 PG 2000 for Coolers up to 3000 BTUS.  
 PG 3000 for Coolers up to 5000 BTUs.  
 PG 6500 for Coolers up to 10000 BTUS.

Our grinders can be supplied with the following optional accessories:

Pedestal and protective windows  
 (These models can be manufactured in special order in 220 volts, single-phase or three-phase).

## Dimensions

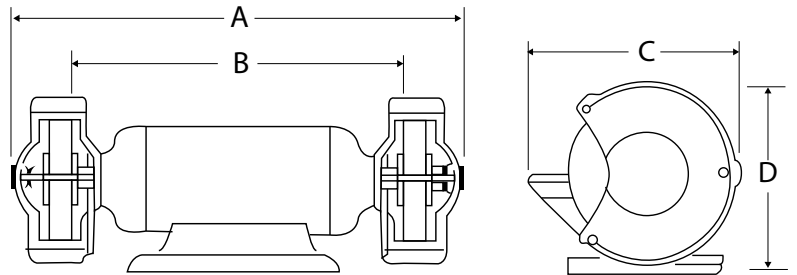

Model	A (in)	B (in)	C (in)	D (in)
EHD-142-1	14.5	14.5	8.9	8.1
EHD-122-1	14.9	11.9	8.9	8.1
EHD-142-1	17.5	13.9	9.5	9.7
EHD-132-1	20.2	14	12.2	12.9

Pedestal	L (in)	M (in)	N (in)	O (in)
P1	10.7	9.3	34	5.1
P3	10.7	9.3	35	5.1

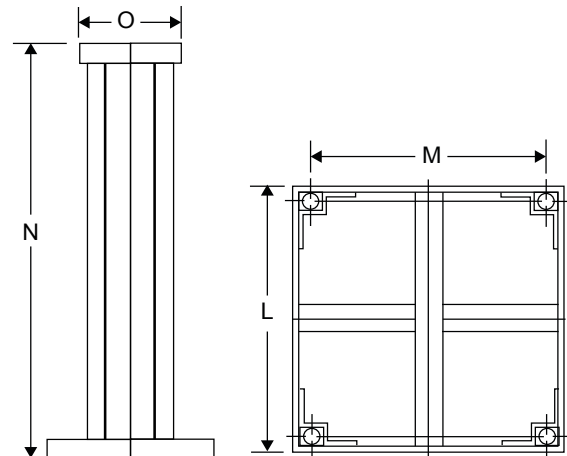

Industria de Motores Eléctricos



AC MOTORS

## Threephasic

# Grinders



### FEATURES

4 Poles Voltages: 220V, 440V, 60Hz

Continuous service for heavy use

Model	EH-324	EH-514
HP	3	5
RPM	1750	1750
Stones (Inches)	355 X 63 mm 14" x 2 1/2"	355 X 76 mm 14" x 3"
Distance between wheels	629 mm 24 25/32"	629 mm 24 25/32"
Shaft Diameter	32 mm 1 1/4"	32 mm 1 1/4"
Height to the center of the shaft	114 mm 4 1/2"	114 mm 4 1/2"
Aprox. Weight (kg.)	119	119

Our grinders can be supplied with the following optional accessories:

Pedestal and protective windows  
(These models can be manufactured in special order in 220 volts, single-phase or three-phase).

### Applications

Three-phase horizontal fully enclosed grinders.  
With bench and pedestal available.  
Continuous service for heavy use.

### Performance

Ball bearings selected for a maximum radial load; gray iron casting hoppers, with side hopper lid.  
They are supplied without abrasive stones.

### Dimensions

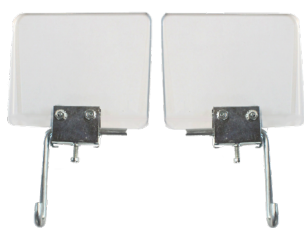

Protective Windows



Pedestal

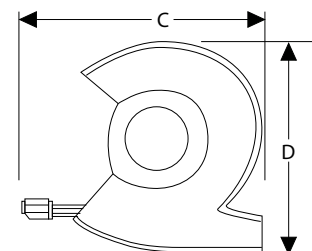
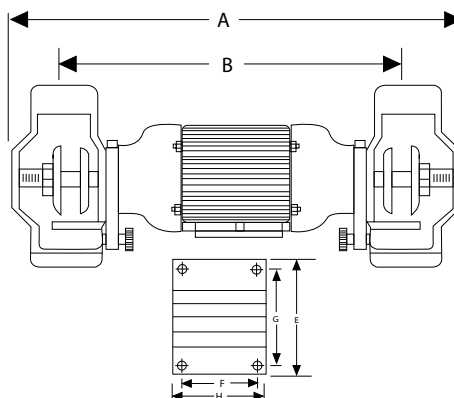

Model	HP	Poles	Dimensions	A	B	C	D	E	F	G	H
EHE-314	3	4	mm	868	608	432	454	232	140	190	178
EHE-514	5		Plg	34 3/16	23 15/16	17	17 7/8	9 1/8	5 1/2	7 1/2	7



Industria de Motores  
Eléctricos